

User guide

Advanced IO

RFID + REL
v.1.1



Contents:

1. System schematic	3
2. Basic parameters	4
2.1. System description.....	4
2.2. System parameters	4
3. Detailed connection schematics	5
3.1. Power supply	5
3.2. Relay outputs	5
3.3. RFID	5
3.4. RS485	6
4. USB interface	6
5. Manual user interface	7
5.1. IO interface parameters	7
5.2. Device information	7
5.3. Settings	8
5.3.1. LAN connection	8
5.3.2. Modbus	8
5.3.3. RTU RS485	9
5.3.4. System settings	9
6. Modbus communication	10
6.1. Factory settings	10
6.2. Modbus registers	11
6.2.1. Input registers	11
6.2.2. Holding registers	12
6.2.3. Coils registers	13
6.2.4. Input discrete registers	13

1. System schematic

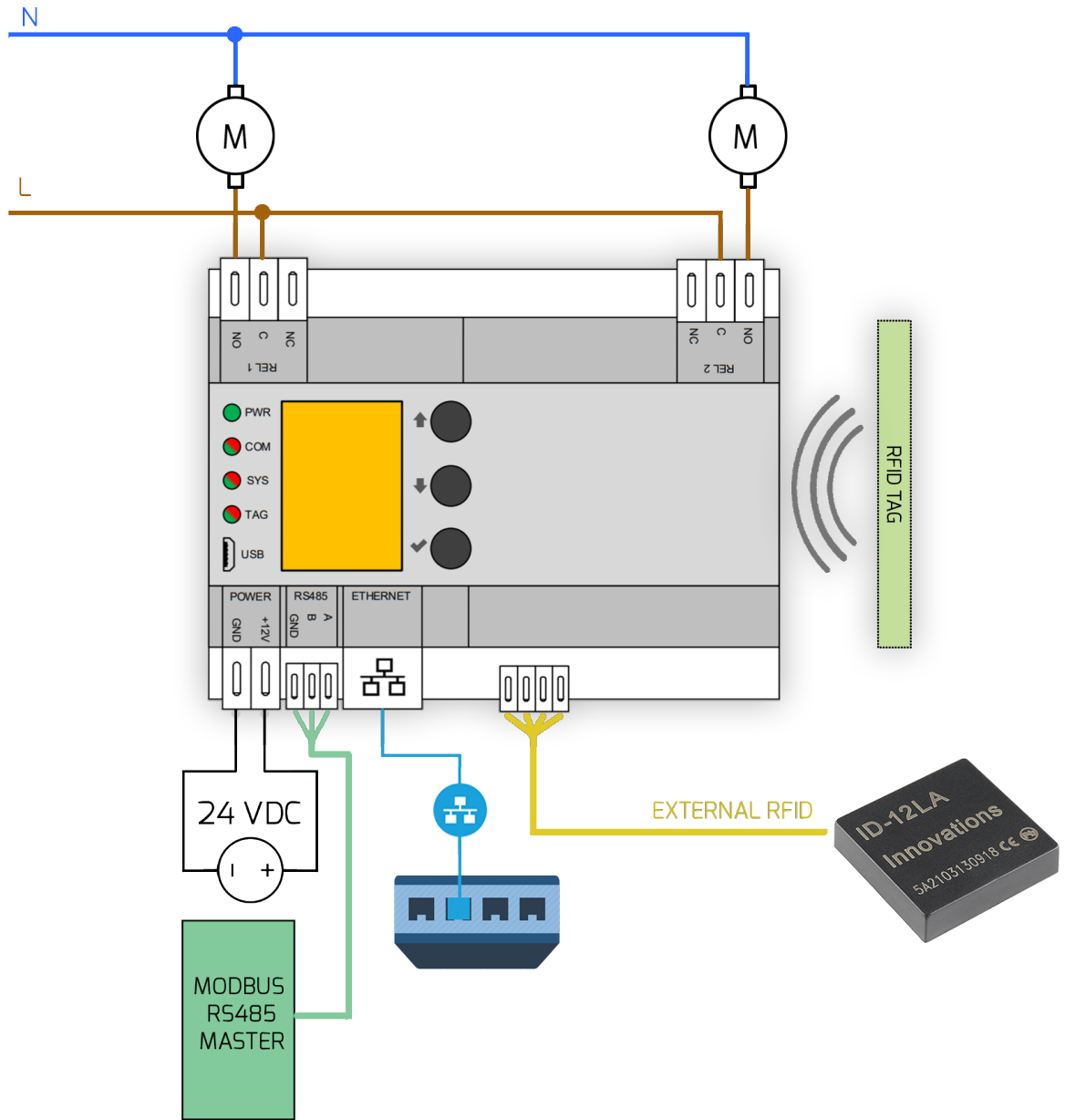

2. Basic parameters

2.1. System description

AdvancedIO RFID + Rel is a compact device intended for automatization of devices with access verification.

Integrated RFID reader can serve for verification, identification and monitoring of people accessing a restricted area, or device operator identification.

An optional external RFID reader can be added.

AdvancedIO RFID + Rel includes 2 relays with a maximum switching current of 5 A and voltage 250 VAC. They can be used for switching electronic devices, opening gates, doors, controlling light signalization, etc.

The whole device can be a part of the Industry 4.0 platform and is controlled through a serial interface RS485 using the industrial communication protocol Modbus/RTU, or through ethernet interface using the industrial communication protocol Modbus/TCP. The integrated display with buttons allows for control of the individual outputs manually, as well as monitoring the state of the inputs/outputs in real-time.

In case a wireless solution is needed, the communication can be executed through Wifi, or one of many radio modules in our selection (434 MHz, 868 MHz, NB-IoT, 3G/GSM, LoRaWAN).

The device can be easily mounted on a DIN rail.

2.2. System parameters

RFID	ISO 125 kHz / MiFare
Communication interface	1 x Ethernet 1 x RS485 1 x WiFi
IO interface	2x relay 250 VAC/5 A
Communication protocols	Modbus/TCP slave Modbus/RTU slave HTTP API (optional)
Optional radio modules	868/434 MHz, LoRaWAN, NB-IoT, 3G/GSM
Temperature range	-20 až +50 °C
Power supply voltage	24 VDC
Power consumption	max. 2 W (without radio module)
Dimensions	108 x 90 x 63 mm
Mount	DIN rail

Relay output	
Maximum load	5 A / 250 VAC
RFID	
Protocol	ISO 125 kHz
Optional	Mifare 1k Mifare 4k Mifare UltraLight NFC NTAG203

3. Detailed connection schematics

3.1. Power supply

The device requires an external DC power supply, able to provide at least 5 W of power at 24 V.

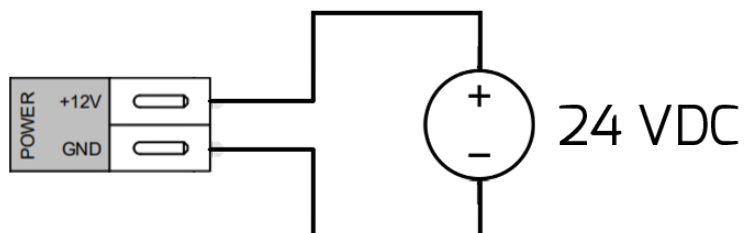

3.2. Relay outputs

Connect the electromagnetic contacts according to the following schematic. The maximum load for alternating current is 5 A/230 VAC

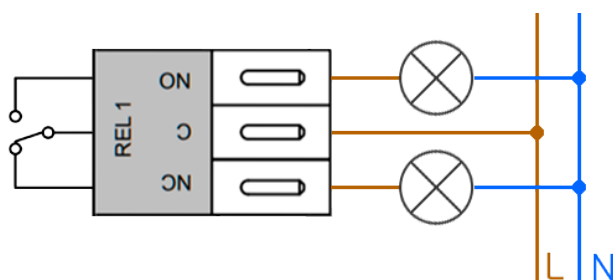

3.3. RFID

Connecting an external RFID reader is possible. According to needs, the customer can choose from our wide range:

- 125 - ISO 125 kHz
- Mifare 1k
- Mifare 4k
- Mifare UltraLight
- NFC NTAG203

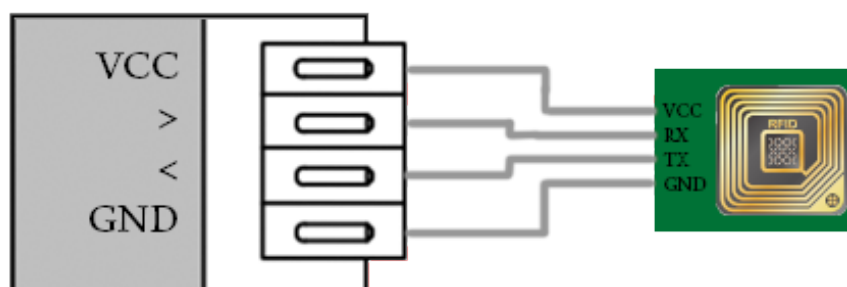

3.4. RS485

RS485 serves communication purposes through the Modbus RTU protocol with the master control unit (chapter 6).

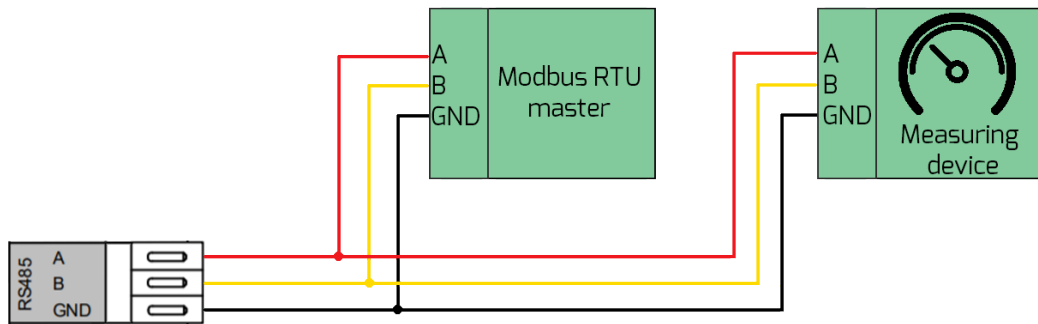

4. USB interface

The interface is intended for maintenance purposes. It is not required in an ordinary workload. After connecting the device to PC it will appear as a virtual COM port. It uses the same commands as TCP server.

USB can be used to update the device firmware (requires special software).

USB interface	
Communication speed	115200 baud
Format	8 bit
Parity	none
Stop bit	1

5. Manual user interface

The device can be controlled manually, using a user interface (operator), or fully automated using Modbus TCP/RTU. All necessary service settings and manual interface options are described in the following sections.

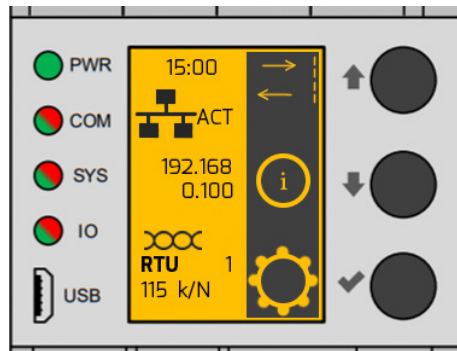

5.1. IO interface parameters

After pressing the "↑" button, a menu opens in which the IO interface can be controlled. The IO interface means: switching and disconnecting devices using relay contacts, reading RFID identifiers.

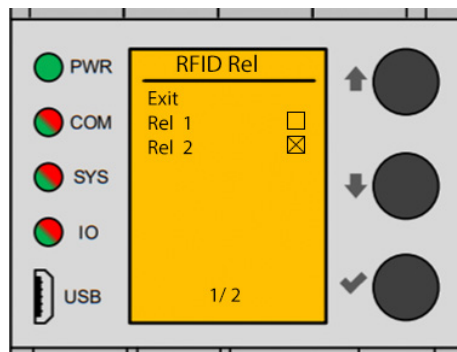

5.2. Device information

Using the "↓" button, the user gets to the menu in which information about the system is available, such as: firmware version, device version, selected radio module, or device temperature. The hardware version is important for the user to know if the new firmware is compatible with his hardware.

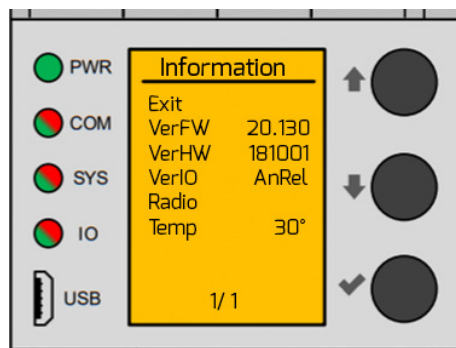

5.3. Settings

Using the "✓" button the user gets to the menu in which he can set the basic parameters of the device, such as LAN connection, WLAN connection, Modbus communication, RTU communication and system settings. All settings will be described in separate sections.

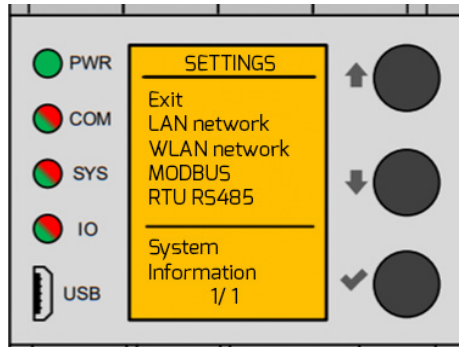

5.3.1. LAN connection

The LAN connection is set in Settings -> LAN network.

When using a LAN connection, it is important to check the "Use LAN" box. Subsequently, the device needs to be restarted (section 5.3.4. System settings), because the change

The user can set the IP address, mask and gateway as needed.

The factory settings are: IP: 192.168.0.100, mask: 255.255.255.0, gateway: 192.168.0.1.

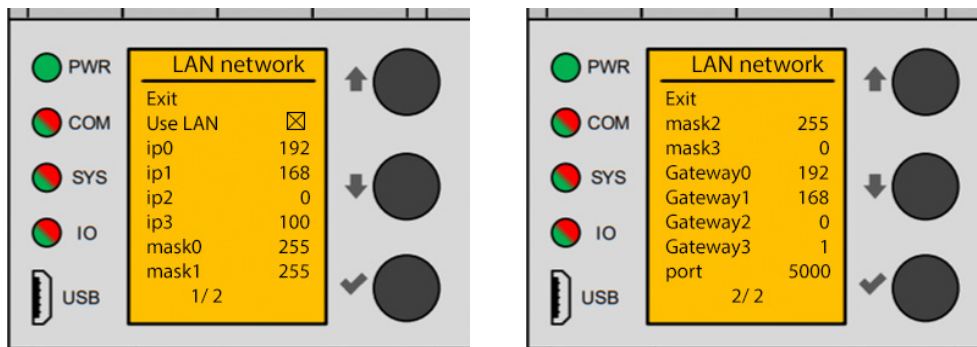

5.3.2. Modbus

Modbus communication is set in Settings -> MODBUS. In the Modbus section, the user can choose the communication method. By checking the TCP en. option, it will be possible to communicate via the Ethernet interface using the Modbus/TCP protocol. The communication port is set in TCP port. By checking the option RTU en., it will be possible to communicate with the Modbus/RTU protocol via the RS485 interface. Setting the address of the device is realized by writing the address to the RTU ad..

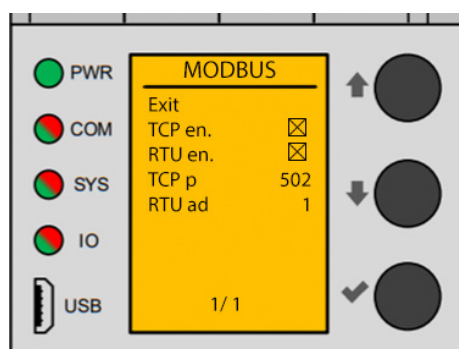

5.3.3. RTU RS485

The RS485 interface is set in Setting -> RTU RS485.

RS485 interface supports Baud rate 9600, 19200, 38400, 57600, 115200. Parity can be set to None, Odd, Even.

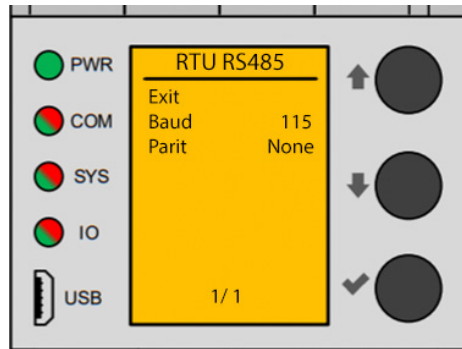

5.3.4. System settings

System settings are implemented in Settings -> System.

The system settings include, for example, the time and date, if the time is not displayed correctly after turning the device off and on, it is necessary to insert or replace the battery in the unit (type CR1220).

LcdBl sets the backlight. The user can choose from three backlight options. Always on, always off or automatic (the backlight turns on when you interact with the unit and turns off automatically, after a certain period of inactivity).

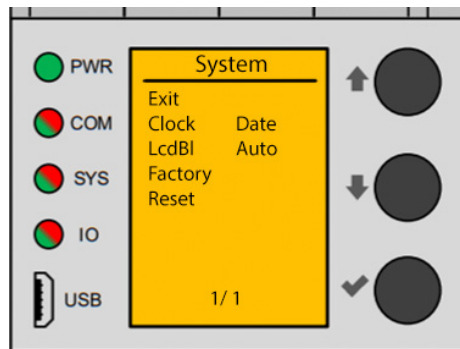

6. Modbus communication

6.1. Factory settings

The entire system can be controlled via Modbus/TCP or Modbus/RTU protocol.

To use Modbus/TCP, it is necessary to connect an Ethernet cable to the AdvancedIO RFID + Rel module (or connect via WiFi). The device in Modbus communication is in the role of Modbus slave. When using several devices in the network, it is necessary to assign a different IP address to each one. Setting a different IP address can be done manually on the device (section 5.3.1.).

Modbus TCP factory settings	
IP address	192.168.0.100
Subnet mask	255.255.255.0
Gateway	192.168.0.1
Modbus port	502

AdvancedIO RFID + Rel can be controlled using Modbus RTU, where it is necessary to connect the differential pairs of Bus RS485 and GND. When using multiple devices, it is necessary to change the RTU address. This action is possible by connecting to the device using modbus TCP and writing the required address in the holding register 20 or setting the address manually on the device (section 5.3.2.).

Modbus RTU factory settings	
RTU address	1
Factory communication settings	
Communication speed	19200 Bits/s
Format	8 Bits
Parity	none
Stop bit	1

6.2. Modbus registers

6.2.1. Input registers

		Data type	Order of registers	RAW unit	RAW range from	RAW range to	OpenDAF address	OpenDAF object type	OpenDAF data type
0	FW version year	uint16			0	65535	\$a/3:1	measurement	integer
1	FW version month	uint16			1	12	\$a/3:2	measurement	integer
2	FW version day	uint16			0	31	\$a/3:3	measurement	integer
3	Temperature	int16		°C	-40	85	\$a/sl1@3:4	measurement	integer
4	Time since last boot (hours)	uint16			0	65535	\$a/3:5	measurement	integer
5	Time since last boot (minutes)	uint16			0	59	\$a/3:6	measurement	integer
6	Time since last boot (seconds)	uint16			0	59	\$a/3:7	measurement	integer
50 - 51	The last address of the RFID card	uint32	little endian	rfid 125kHz ID	0	4294967295		measurement	
52 - 53	Reserved	reserved	little endian					measurement	

(\$a - unit address)

6.2.2. Holding registers

		Data type	RAW range from	RAW range to	OpenDAF address	OpenDAF object type	OpenDAF data type
0	IP address of device, first octet (standard: 192)	uint16	0	255	\$a/4:1	measurement / command	integer
1	IP address of device, second octet (standard: 168)	uint16	0	255	\$a/4:2	measurement / command	integer
2	IP address of device, third octet (standard: 0)	uint16	0	255	\$a/4:3	measurement / command	integer
3	IP address of device, fourth octet (standard: 100)	uint16	0	255	\$a/4:4	measurement / command	integer
4	IP subnet mask, first octet (standard: 255)	uint16	0	255	\$a/4:5	measurement / command	integer
5	IP subnet mask, second octet (standard: 255)	uint16	0	255	\$a/4:6	measurement / command	integer
6	IP subnet mask, third octet (standard: 255)	uint16	0	255	\$a/4:7	measurement / command	integer
7	IP subnet mask, fourth octet (standard: 0)	uint16	0	255	\$a/4:8	measurement / command	integer
8	IP gateway, first octet (standard: 192)	uint16	0	255	\$a/4:9	measurement / command	integer
9	IP gateway, second octet (standard: 168)	uint16	0	255	\$a/4:10	measurement / command	integer
10	IP gateway, third octet (standard: 0)	uint16	0	255	\$a/4:11	measurement / command	integer
11	IP gateway, fourth octet (standard: 1)	uint16	0	255	\$a/4:12	measurement / command	integer
12	TCP port of modbus communication (standard: 502)	uint16	1	65535	\$a/4:13	measurement / command	integer
13	MAC address, first octet	uint16	0	255	\$a/4:14	measurement / command	integer
14	MAC address, second octet	uint16	0	255	\$a/4:15	measurement / command	integer
15	MAC address, third octet	uint16	0	255	\$a/4:16	measurement / command	integer
16	MAC address, fourth octet	uint16	0	255	\$a/4:17	measurement / command	integer
17	MAC address, fifth octet	uint16	0	255	\$a/4:18	measurement / command	integer
18	MAC address, sixth octet	uint16	0	255	\$a/4:19	measurement / command	integer
19	TCP port of text protocol communication (standard: 5000)	uint16	1	65535	\$a/4:20	measurement / command	integer
20	Modbus RTU RS485 address	uint16	1	254	\$a/4:21	measurement / command	integer
21	Modbus RTU RS485 communication speed (change applied after reset) 0 - 9600 1 - 19200 2 - 38400 3 - 57600 4 - 115200	uint16	0	4	\$a/4:22	measurement / command	integer
22	Modbus RTU RS485 parity (change applied after restart) 0 - None 1 - Even 2 - Odd	uint16	0	2	\$a/4:23	measurement / command	integer

(\$a - unit address)

6.2.3. Coils registers

		Data type	RAW range from	RAW range to	OpenDAF address	OpenDAF object type	OpenDAF data type
3	Discovery of the device (LEDs on the outputs will flash for 20 seconds)	bool	0	1	\$a/0:4	measurement / command	binary
50	Relay output 1	bool	0	1	\$a/0:51	measurement / command	binary
51	Relay output 2	bool	0	1	\$a/0:52	measurement / command	binary
54	Resetting the accumulated energy registers	bool	0	1	\$a/0:55	measurement / command	binary

(\$a - unit address)

6.2.4. Input discrete registers

		Data type	RAW range from	RAW range to	OpenDAF address	OpenDAF object type	OpenDAF data type
50	Digital input 1	bool	0	1	\$a/1:51	measurement	binary
51	Digital input 2	bool	0	1	\$a/1:52	measurement	binary
52	Digital input 3	bool	0	1	\$a/1:53	measurement	binary
53	Digital input 4	bool	0	1	\$a/1:54	measurement	binary

(\$a - unit address)



T-Industry, s.r.o.
Hoštáky 910/49
907 01 Myjava
Slovenská Republika

tel.: +421 69 200 1178
mob.: +421907 712 955
web: www.tind.sk
emial: tind@tind.sk



EEaS, s. r. o.
Primátorská 296/38
180 00 Praha 8
Česká republika

mob.: +420 731 480 348
web: www.eeas.cz
emial: info@eeas.cz

